

# DATA SHEET HEXAGON SWING SETA

Text for invitation to tender | Item No: 51 2025 401



## MATERIALS | SCOPE OF SUPPLY

Swing, mounted on-location, fixation of the chains and swing bars necessary

Post:	stainless steel, V2A, 6 pieces
Swing bar:	stainless steel, V2A, 3 lower parts; 3 upper parts
Swing seat:	EPDM caoutchouc with steel inlay, each with jump protection, 6 pieces
Chains:	stainless steel 1,70 m (3x 2 pieces) 1,90 m (3x 2 pieces)
Tube end caps:	plastic, 18 pieces

## TECHNICAL INFORMATION

Dimensions:	
Main dimension:	5485 x 4755 mm
Height:	2760 mm
Weight:	421 kg
Capacity:	acc. to normative requirements
Dimension largest piece:	300 x 100 x 3620 mm
Heaviest piece:	42 kg
Max. fall height:	1500 mm
Impact protection	
Impact area:	56,74 m <sup>2</sup>
Required safety slabs:	65,00 m <sup>2</sup>
Required lawn grating:	68,00 m <sup>2</sup>
Recommended surface material:	sand, wood chip, gravel, synth. impact protection

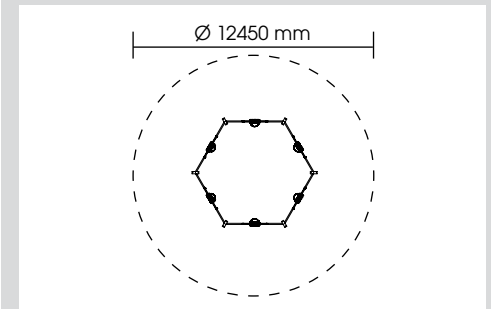

## INSTALLATION

Foundations: 6

Installation according to our detailed mounting instructions, see [www.stilum.com](http://www.stilum.com)

